

LEVEL INVERTER FOR REGULATED POWER SUPPLY FROM DC GENERATOR

K. NAYANI, *Department of EEE,*
Dr. P. SRAVAN KUMAR, *Associate Professor & HOD,*
SREE CHAITHANYA INSTITUTE OF TECHNOLOGICAL SCIENCES, KARIMANGAR.

ABSTRACT: An inverter with five customizable parameters is typically employed to convert direct current (DC) into alternating current (AC). There are specific conditions in which the 5-level inverter/converter can only receive $\pm 2 V_{dc}$ from the load. In order to create the voltage, which is an alternating current output, the CPU often modifies the voltage. This cause-and-effect relationship is made feasible by the method's capacity to reduce THD levels. Some things just can't be done when you combine a high frequency rate with high power and voltage. These limitations are sometimes caused by switching losses or the restrictions of the device's rate of operation. To accommodate variations in power, a five-level inverter generates an alternating current signal. A stepped waveform, which goes more gently, can be achieved by adding voltage levels that rise slowly. To do this, the inverter configuration must permit voltage increase while reducing dv/dt . An increase in the number of voltage levels results in a more stable output pattern. A more sophisticated inverter controller is required as the design hierarchy progresses due to the increased number of switches and components.

Keywords: H-bridge Five level Inverter, THD, Matlab/Simulink

1. INTRODUCTION

The incorporation of transformers for power electronics into industrial motor systems is rapidly becoming an indispensable component. This can be attributed, in large part, to the fact that they are dependable in terms of carrying out the task for which they were built. For applications that demand high voltage, low harmonic distortion, and high power, the H-bridge five-level inverter has garnered a substantial amount of interest in recent years. This interest has been fueled by the fact that it is a five-level inverter. There are a variety of sources that have contributed to the development of this interest. The dramatic rise in popularity of the inverter can be attributed to a number of things, one of which is this curiosity. The introduction of new technological

breakthroughs is one of the most important causes that has led to this growth, and it is also one of the factors that has contributed significantly to the expansion of this excitement. In spite of the fact that this is the case, it is not absolutely out of the question that the application might be able to fulfill all of these requirements. When there is a substantial quantity of harmonic distortion, there is a possibility that the grid voltage synchronization will be broken. This is a possibility. Additionally, when the efficiency of the inverter is destroyed, the amount of time that the inverter is able to function at its peak performance is lowered. This time period is referred to as the "peak performance time." More specifically, this is because the inverter will need more time in order to reach its full potential in terms of

performance. In order to properly limit the amount of harmonic distortion that is generated by a traditional converter, it is essential to have a filter that is of a very large size. It is necessary for the filter to be of a size that is exceedingly substantial in order to achieve this goal. The fact that the distortion starts in the converter is evidence that this is, in fact, the condition that exists. The fact that this is a direct result of the condition is what causes the overall size of the system to rise by a large amount. This is the cause of the increase. By deploying a collection of stacked inverters that are able to perform at high voltage levels while exhibiting minimum harmonic distortion, we were able to reduce the footprint of the inverter. This allowed us to save space. As a result of this, we were able to decrease the overall size of the system throughout its entirety. Because of this, we were successful in accomplishing our goal of increasing the amount of work that we produce. This particular element made it possible for us to minimize the size of the inverter that we would be using, which was a significant benefit. Because of this, we were able to significantly reduce the size of the inverter, which allowed us to reach a form factor that was more portable.

2. LITERATURE SURVEY

Traditional inverters with a higher harmonic content can mitigate the total harmonic distortion produced by DC renewable energy sources, such as solar and wind power systems, according to multiple research.

Information gathered in 2014 by Md. Linton Hossain and Zulkifilie bin Ibrahim. By utilizing suitable architectural and management solutions, harmonic

distortion can be reduced. In order to improve voltage quality and reduce harmonics, several multilayer inverter topologies were investigated. Diode clamping, capacitor clamping, and H-bridges are the most common inverter topologies. The system will become heavier and more burdensome as the size of the components increases due to an increase in capacitance in the diode-clamped inverter and capacitor. By doing away with the need for clamping using capacitors or diodes, the cascade H-bridge multilevel inverter technology solves the problem. A cascading H-bridge inverter with five stages is modelled in this research. Despite its understated appearance, this inverter produces a substantial amount of power.

In line with what P. Yoganand Reddy and MLN Vital found (2016). A single-phase multilevel inverter contains DC sources for each of its phases. A positive, negative, and neutral voltage is produced at every level. You can get what you want by connecting the DC output to a power source and playing around with the four switches. To activate the inverter, it is necessary to have two switches in opposite positions that are both turned on. When the other inverters are turned on or off, it will turn off automatically. Determine and use switching angles to reduce overall harmonic distortion. On the fifth level of the H-bridge inverter, you'll find a cascade arrangement of two inverters. Unlike the traditional multilevel inverter, which uses four switches to control the output voltage, this inverter has five levels of output and eight switching devices.

This inverter, according to Vinayaka B.C. and S. Nagendra Prasad (2014), generates a sinusoidal voltage through the sequential

connection of five H-bridge inverters. The article delves into this topic. As a whole, the voltage that each cell produces is equal to the sum of its individual voltages. Inverters go by a few different names, including H-bridge and single-phase full-bridge. By connecting the DC source to the AC output through one of four possible switch configurations (S1, S2, S3, and S4), the inverter level generates +Vdc, 0Vdc, or -Vdc. While switches S3 and S4 can produce -Vdc, switches S1 and S2 can produce +Vdc. When there is no voltage at the circuit's output, switches S1 and S2 (or S3 and S4) are turned on. The -Vdc output is generated by switching on S7 and S8, whereas the +Vdc output is achieved by activating S5 and S6. A voltage waveform is produced by adding together the AC outputs of all the stages in a full-bridge inverter. The total voltage generated by all of the cells is equal to the sum of their individual voltages. The output voltage can take on any of $2n+1$ values for every given n (number of cells). Modulating the switching angles allows one to regulate the amount of harmonic distortion produced. A cascaded H-bridge multilevel inverter with n levels requires $2.5n$ switching devices, where n is the number of steps in the output voltage.

Research conducted in 2015 by Purvi B. Anghan, Archan B. Patel, Chandni M. Vora, and Vipul J. Anghan. One type of control used in multilevel inverters is a cascaded multilevel inverter. The term "series H-bridge inverter" might describe this controller as well. There is no need for clamping diodes or capacitors to maintain voltage homeostasis because of the design of this architecture. In order to prevent DC source short circuits, cascaded multilevel inverters use a separate DC source

configuration from the rest of the device. Because each DC source is independent, the series multilevel inverter works well with a wide variety of renewable energy technologies. The best way to change active power from alternating to direct current, or vice versa, is via a series multilevel inverter. Because of its adaptability and speed, the cascaded multilevel inverter is the best option for high-power applications. The proposed multilevel inverter design has many benefits over other topologies, including simplified control, reduced switching complexity, and an optimized layout, all thanks to the use of similar building blocks across all levels. Cascading inverters is a solution to multiple issues with H-bridge inverters.

3. MATERIAL AND METHOD

As soon as you have finished reading these articles, you should immediately start giving some thought to a wide variety of different issues at the same time. Start right away. For the purpose of providing an explanation, two examples of these characteristics are the switch control mechanism of the cascading H-bridge inverter and the elimination of harmonic distortion. Both of these characteristics are instances of qualities that belong to separate categories. These two components are examples of the numerous diverse characteristics that are present with the product. In the event that a person makes the decision to get associated with renewable energy sources (RES), it is of the utmost importance for them to ensure that they take into consideration one of the two primary elements that are important. It is not possible to overestimate the significance of this in any way that is even substantially relevant to the topic at hand.

Taking into account the fact that this is the circumstance, it is of the utmost importance to put in place a system that is capable of bringing out the best in each of these components independently of where they are in relation to one another. It is possible to provide an explanation for this particular facet of the circumstance by making use of the line of reasoning that was shown earlier in the presentation.

Blockdiagram

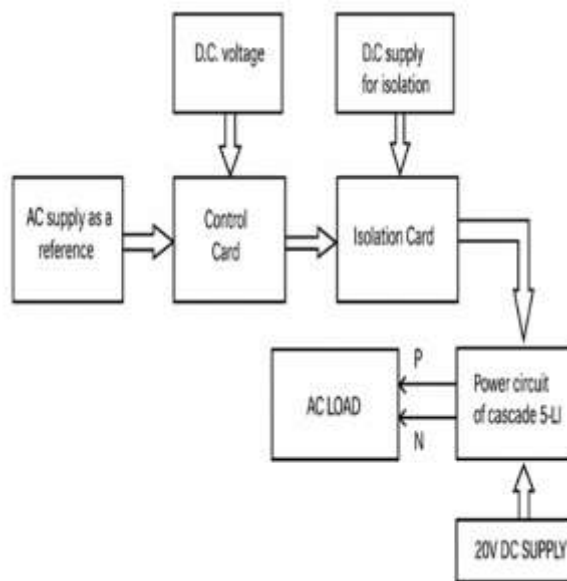

a) Block schematic for a five-level inverter

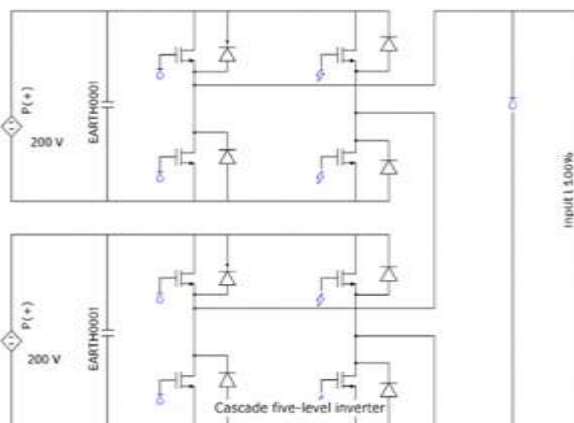

b) Circuit of control

Control Method

In the five-stage inverter, the control circuit is responsible for effectively controlling harmonic distortion. This

obligation falls under the control circuit's purview. There are eight switches contained within the control circuit, and each of these switches is responsible for delivering a uniquely varied voltage. They are equipped with three different voltage outputs, which are as follows: +Vdc, 0Vdc, and -Vdc. " There are a number of different approaches that can be applied in order to build a connection between the DC input and the AC output. These approaches can be utilized through the eight switches, which are designated as S1, S2, S3, S4, S5, S6, S7, and S8. In the event that the output voltage is getting close to zero, the switches S3, S4, S7, and S8 will be actuated at the locations that have been predetermined for them. In order to activate all of the switches S1, S3, S7, and S8 simultaneously, the output voltage must be set to V. This will accomplish the desired result. In the event that the output voltage is more than 2V, the only switches that will become active are switches S1, S3, S5, and S7, in that order. Switches S2, S4, S7, and S8 are responsible for ensuring that the ON status is maintained during the entirety of the -V phase. It has been determined that the activation of switches S2, S4, and S6 is necessary in order to keep the output voltage at -V2. For the switch to be able to successfully minimize harmonic distortion and guarantee that the output voltage is generated in the appropriate manner, it is required to perform exact calibration on the switch. By implementing this method, you will be able to considerably extend the period of time that your machine will continue to function.

Advantages

It is anticipated that the implementation of this will result in an enhancement of the

waveform's quality, which in turn will lead to a decrease in the total harmonic distortion and an extension of the lifespan of the equipment. With regard to the amount of strain that is linked with system switching, there is a correlation between the number of switches and the amount of strain. The number of voltages that are output is significantly higher than the number of sources, which is more than twice as many. However, in addition to this, it simplifies the process of utilizing gadgets that operate on low voltage.

4.CONCLUSION

There is a relationship that may be described as an inverse correlation between the total amount of stress that each device is subjected to as a result of its operation and the number of levels in dv/dt and %THD. When there is an increase in the number of switches, there is a corresponding drop in the voltage that is present across each specific device. As a result of this, switching losses are reduced, which ultimately leads to an increase in the converter's efficiency. This is one of the consequences of this. To get rid of the harmonics that have been chosen, all that is required is to make adjustments to the pulse width. In light of the fact that total harmonic distortion (THD) is directly proportional to the voltage level differential, the pulse width can be altered in order to ascertain the threshold for total harmonic distortion (%THD). Due to the fact that THD is equal to the voltage level difference, this is technically feasible.

REFERENCES

1. Hemant Joshi, P. N. Tekwani, and Amar Hinduja, "Implementation of a Five-Level Inverter Using Reversing

Voltage Topology: A Competitive Solution for High-Power IM Drive Applications," National Power Electronics Conference, 2010.

2. M. P. Rathod, N. K. Jaiswal, Shah Dhara, Vanikar Shantanu, Langalia Pooja, and Patel Sujal, "Reduction in %THD Using Multilevel Inverter," National Conference PEPCCI'14.
3. José Rodríguez, Jih-Sheng Lai, and Fang Zheng Peng, "Multilevel Inverters: A Survey of Topologies, Controls, and Applications," IEEE Transactions on Industrial Electronics, vol. 49, no. 4, Aug. 2002.
4. Andreas Nordvall, "Multilevel Inverter Topology Survey," Master of Science Thesis in Electric Power Engineering, Chalmers University of Technology, Göteborg, Sweden, 2011.
5. Yashobanta Panda, "Analysis of Cascaded Multilevel Inverter Induction Motor Drives," Department of Electrical Engineering, National Institute of Technology, Rourkela.
6. C. Gnanavel, N. Kamalamoorthy, and V. Prabhu, "Assessment Among Single and Three Phase 14-Echelon Cascade Multilevel Inverter," International Journal of Scientific and Research Publications, vol. 3, issue 5, May 2013, ISSN 2250-3153.